



# Incident Investigations

## Key Findings and Learnings

**Oil Industry Safety Directorate**

## Contents

- Incidents Snapshot- 2022
- Causes of incidents
- Incident investigation
- Incident Analysis
- Case studies
- Suggestions for Safety improvement
- conclusion

## 2022 Significant Process Safety Incidents



Coal Mine Explosion in Columbia



Toxic gas leak at Jordan's Aqaba



Leverkusen blast: German chemical plant



South Korea Oil Refinery explosion



Wharton fire: Flames reignite



Fire rages at Cuba oil terminal



## More - 2022 Significant Process Safety Incident



Firecracker manufacturing unit explosion in Tamil Nadu, 11/11/2022



Large explosion in Taiwan's CPC Dalin oil refinery,, 10/28/2022



Turkey coal mine explosion kills 41, injures 11, 10/15/2022



Oil rig explosion injures three workers in North Dekota, 9/13/2022,



Eight injured in fiery blast at idled Canadian oil refinery, 9/2/2022



4 Workers Killed, Surat Chemical Factory Fire , 9/11/2022

# About Incidents

## ❑ Nature of incidents in Hydrocarbon Industry

- a) Fire    b) Explosion and    c) Toxic release

## ❑ What causes an incident ?

- Cognitive bias: At different levels
- Normalization of Deviation-Collective
- Others (natural disaster, sabotage etc)

## ❑ The incident Process

- Initiation
- Propagation
- Termination



# Incident investigation

- Introduction
- Process description
- Incident description
- Investigation results
- Discussions
- Conclusion
- Layered recommendations
  - Immediate Technical recommendation
  - Recommendation to avoid Hazards
  - Recommendation to improve the management system

## Incident Analysis (based on OISD Data)

तेल उद्योग सुरक्षा निदेशालय

Oil Industry Safety Directorate

# Incidents and fatalities in Refineries and GPPs during the last 5 years

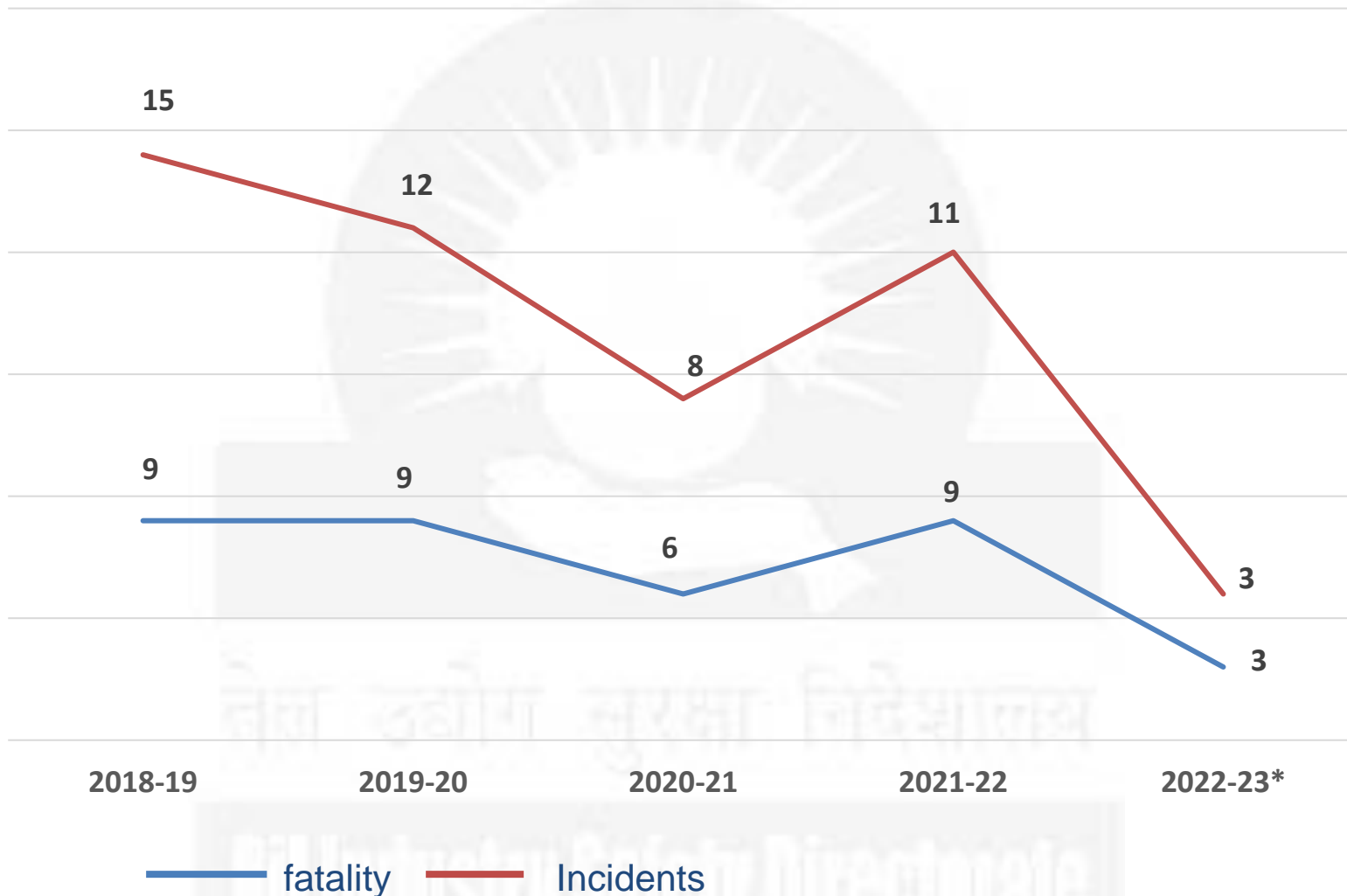

\*Data are taken up to January 2023

# % Distribution of Root Cause

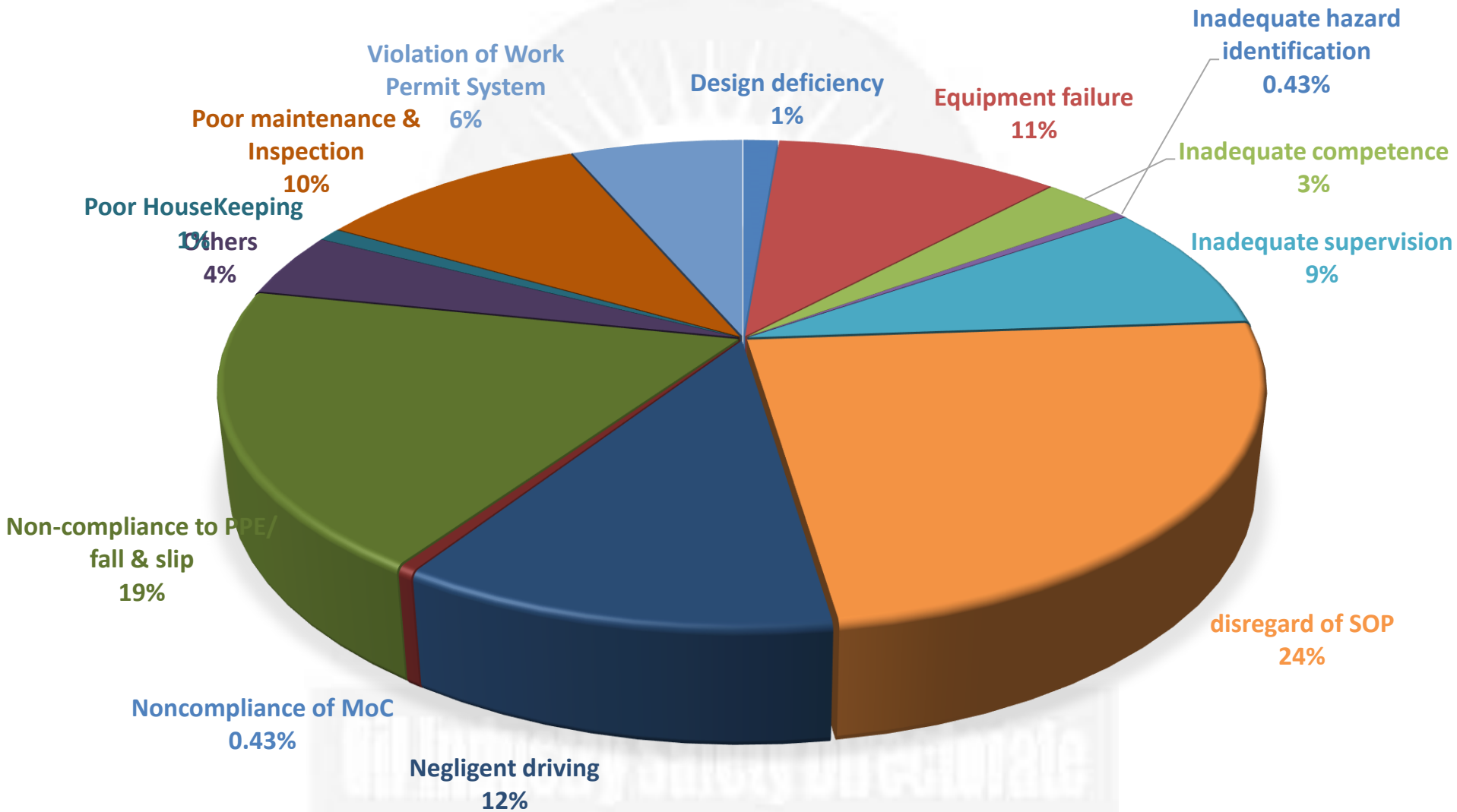

# Fatalities in Refineries and GPPs during last 10 years

## Fatalities in last 10 years

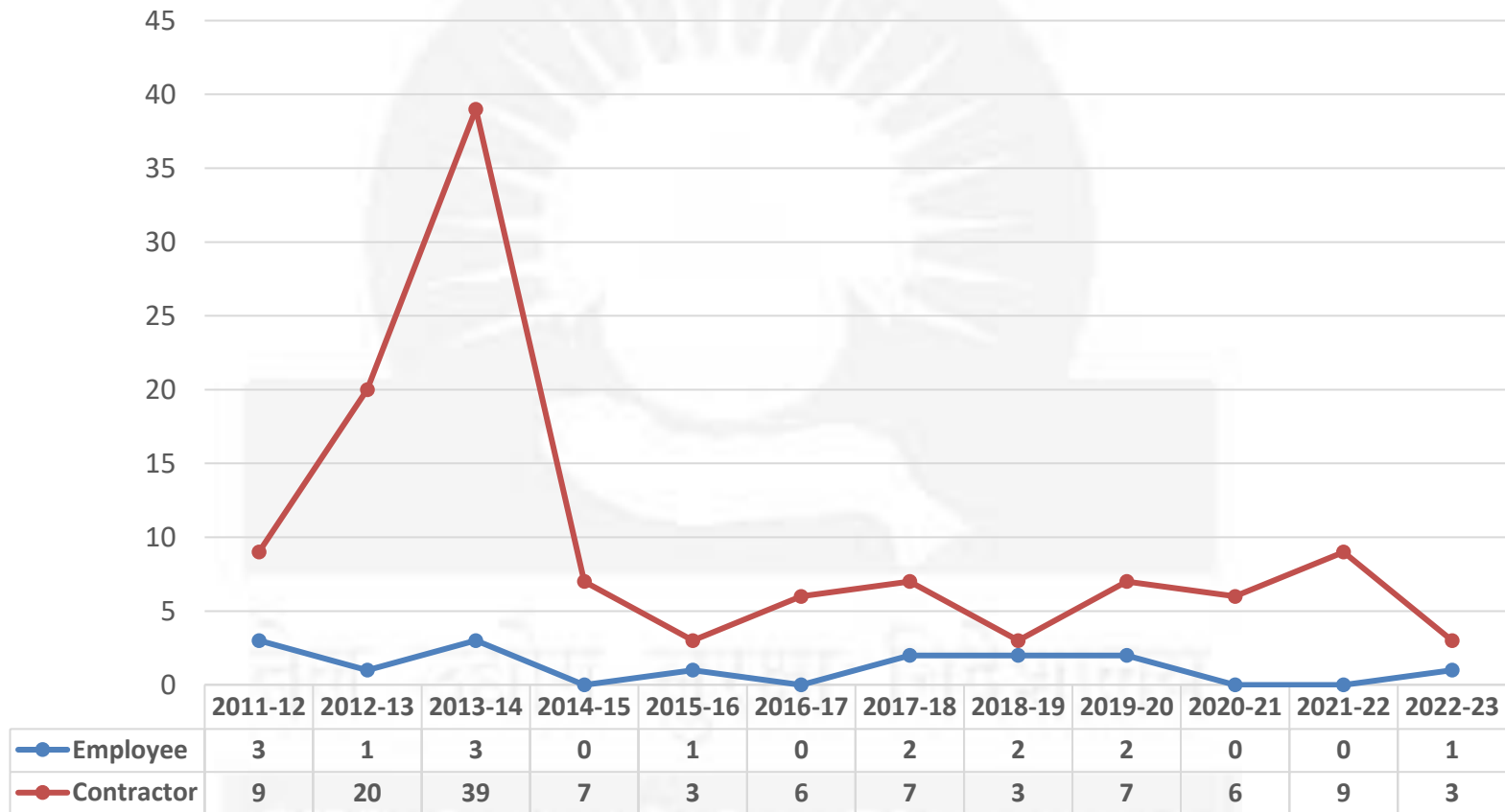

\*Data are taken up to January 2023

# Fatalities due to various Root Causes

| Root Cause                              | Employees | Contract workers |
|---|-----------|------------------|
| Design deficiency                       | 0         | 1                |
| Equipment failure                       | 2         | 3                |
| Inadequate competence (3%)              | 0         | 7                |
| Inadequate supervision (9%)             | 0         | 16               |
| disregard of SOP(24%)                   | 11        | 66               |
| Negligent driving(12%)                  | 3         | 22               |
| Noncompliance of Management of Change   | 0         | 0                |
| Non-compliance to PPE/ fall & slip(19%) | 4         | 37               |
| Violation of Work Permit System (6%)    | 0         | 15               |
| Poor HouseKeeping                       | 0         | 1                |
| Poor maintenance & Inspection(10%)      | 2         | 9                |
| Others                                  | 1         | 8                |
| Grand Total                             | 23        | 185              |

# No. of Incidents during various types of activities

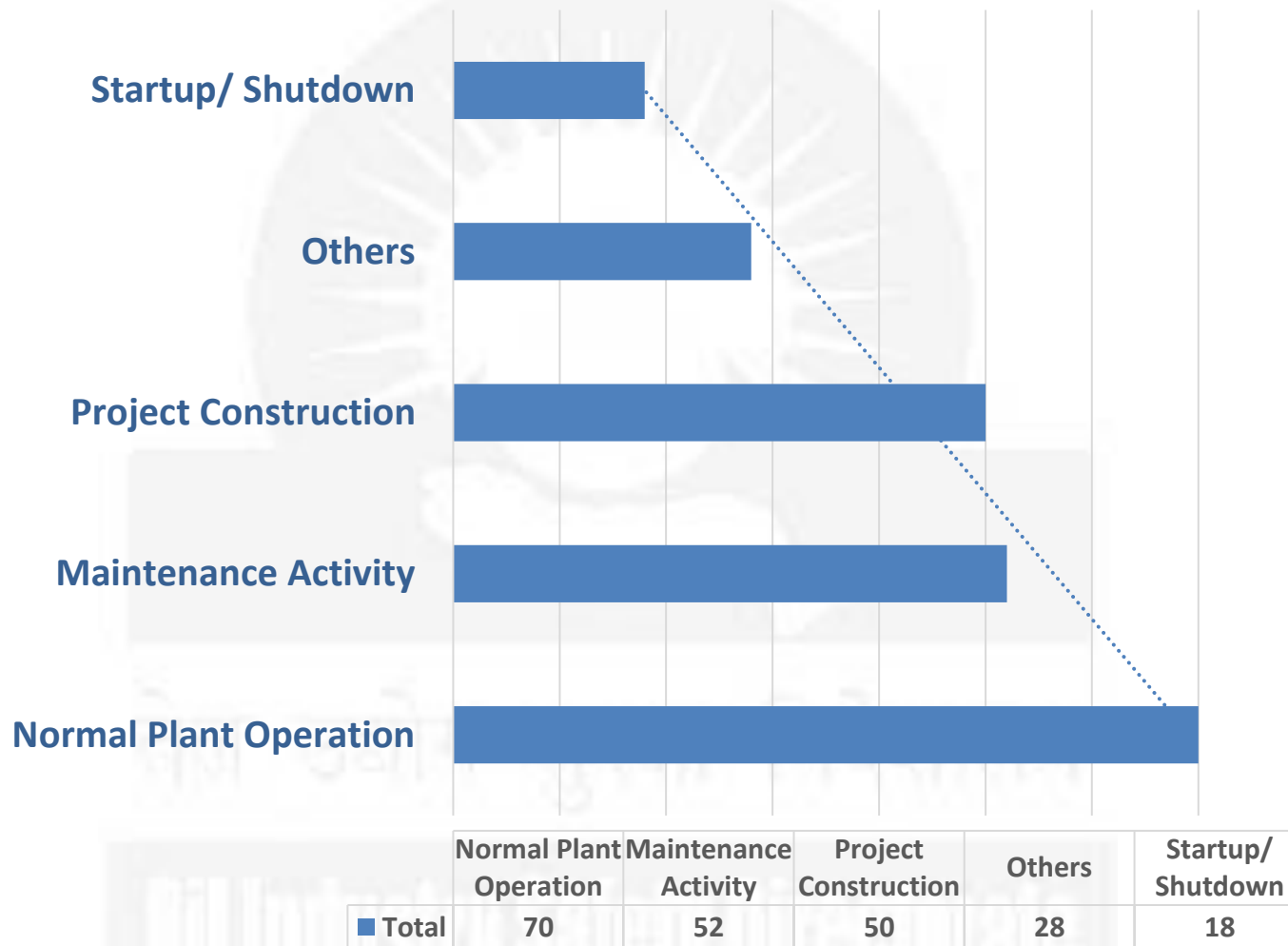

## Fatalities during various activities

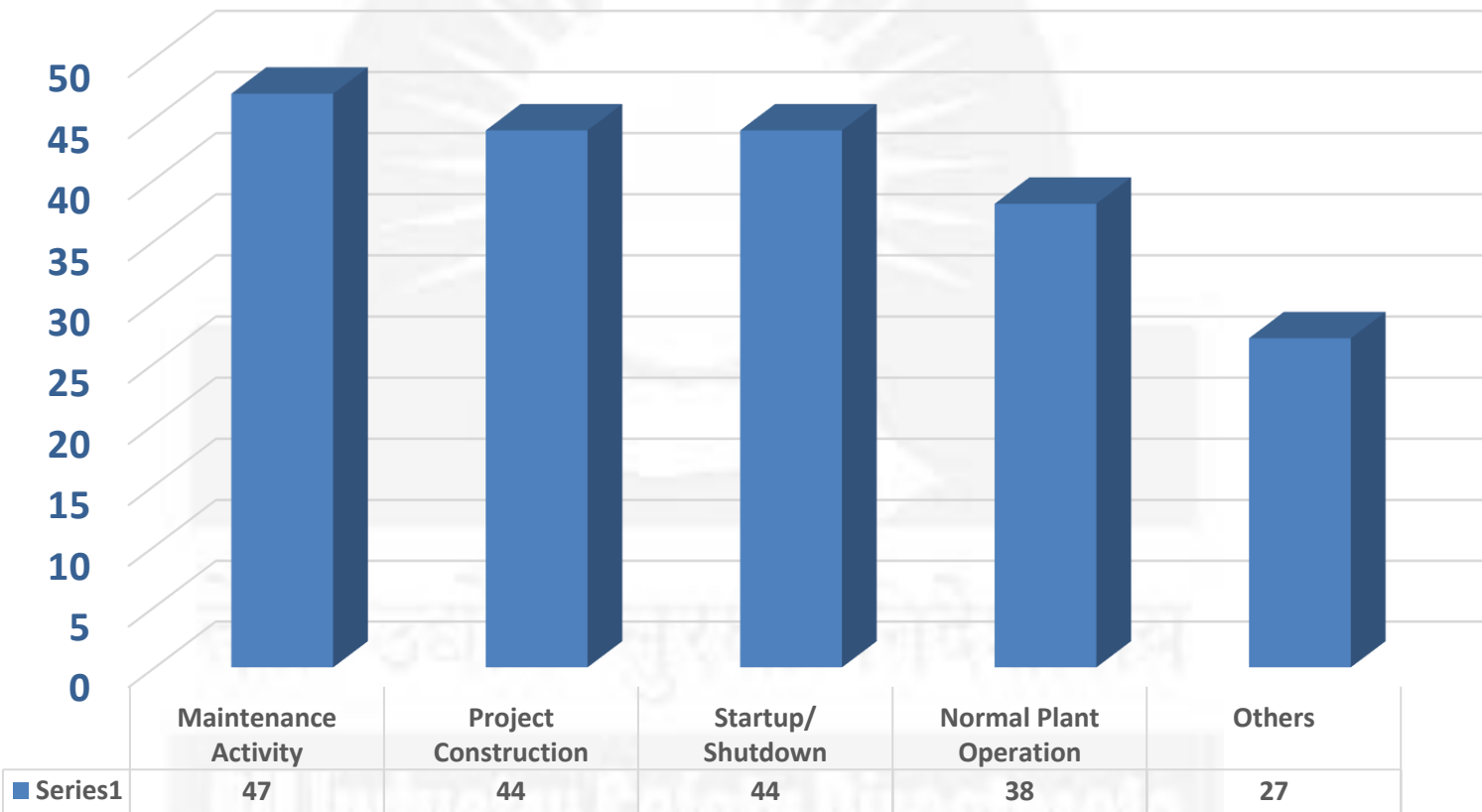

# Degree of risk based on Fatality

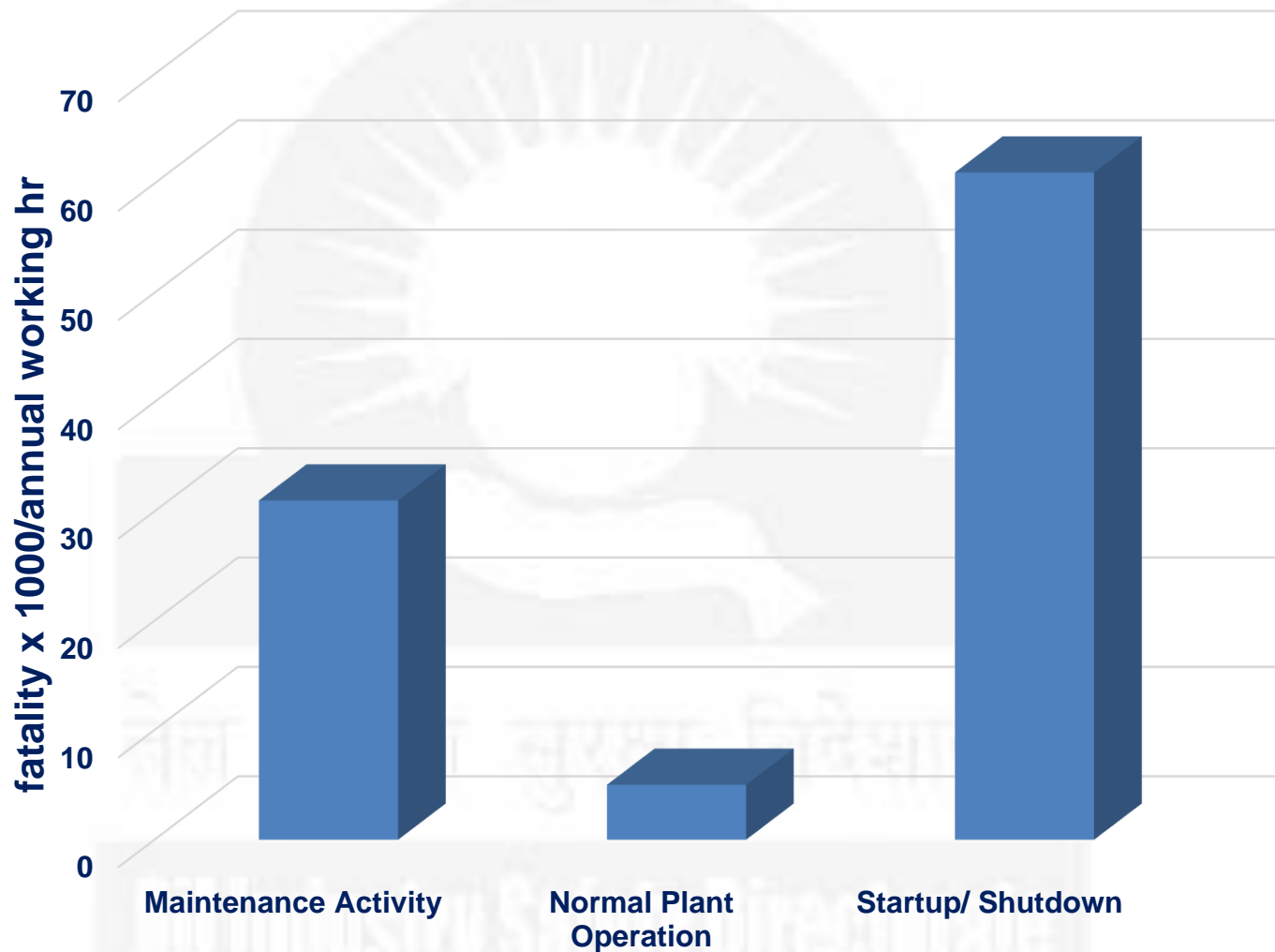

## Case Studies

तेल उद्योग सुरक्षा निदेशालय

Oil Industry Safety Directorate

# Furnace Blast

An incident of an explosion inside the vacuum column furnace of Atmospheric Vacuum Unit during light up of the burner, causing damage to the furnace and injuries to the personnel.

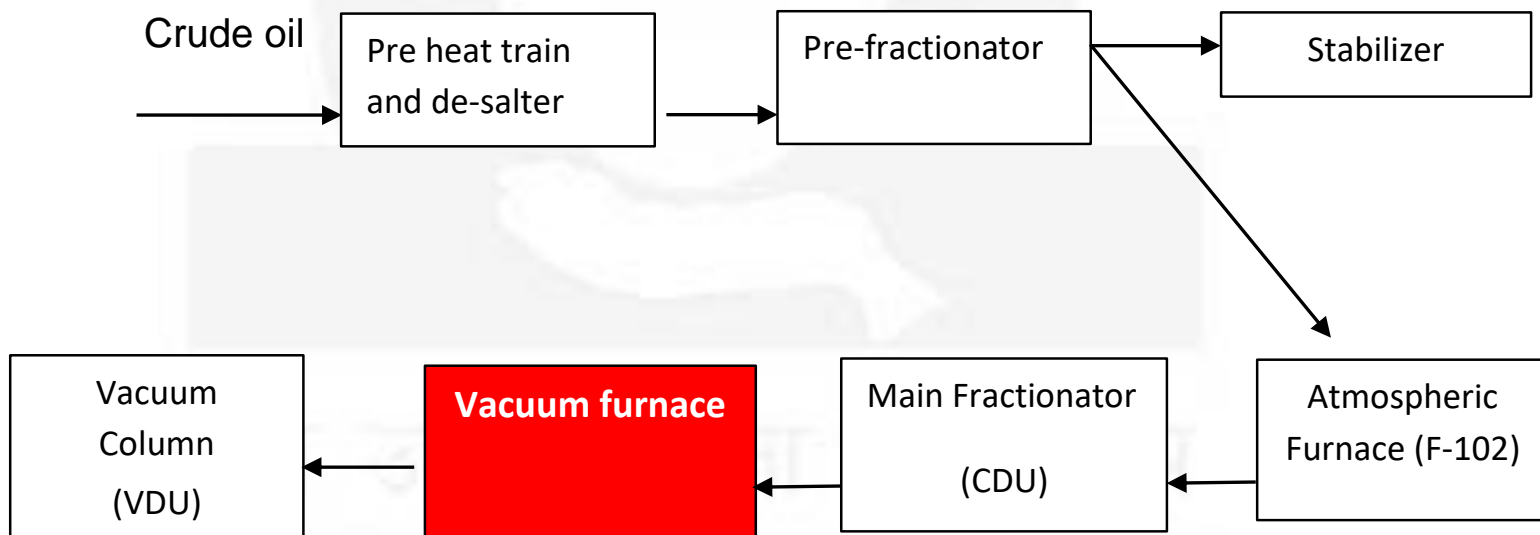

# After



# After blast



# Fuel system

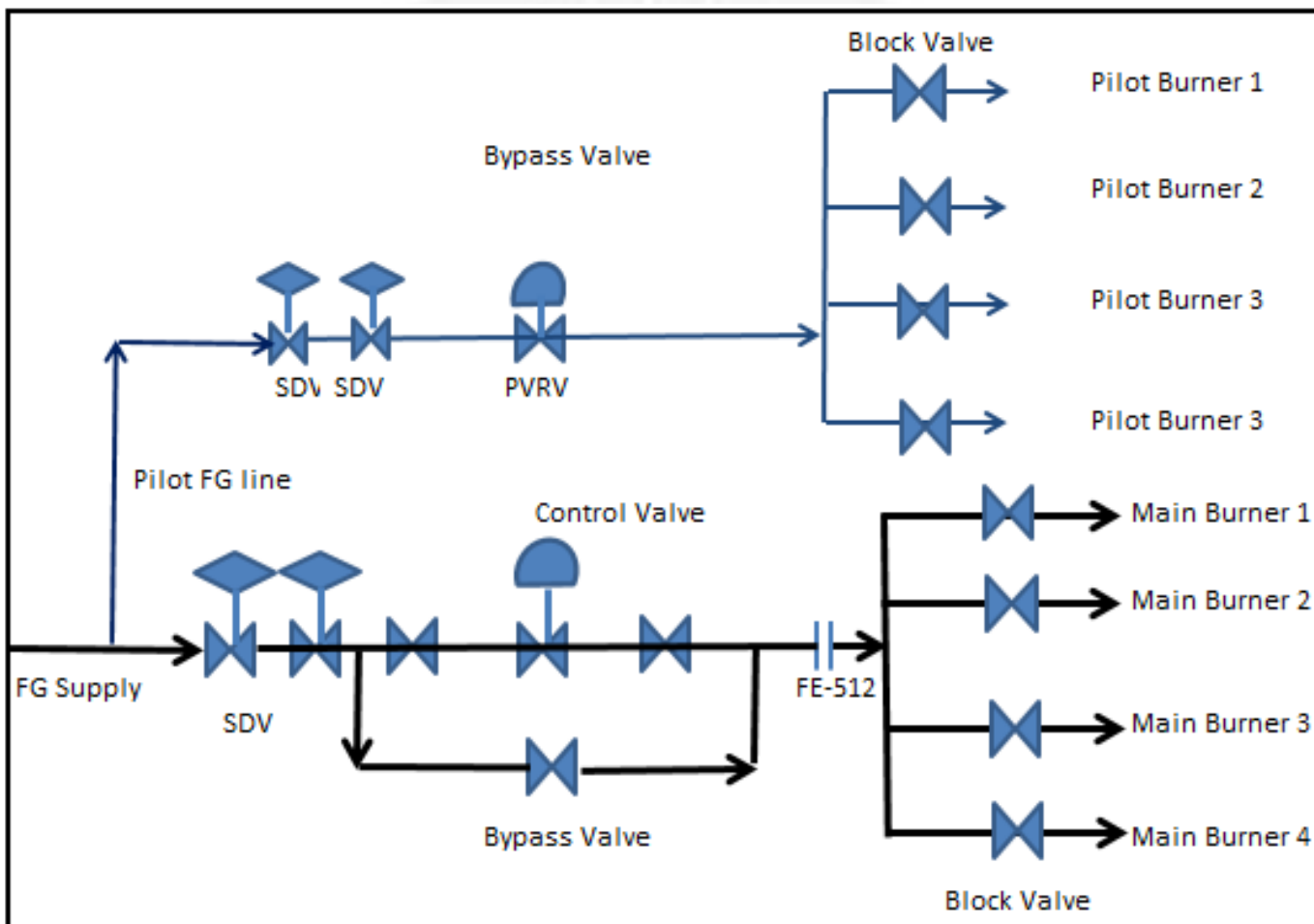

# Major Observations

- ✓ There was unobstructed flow & accumulation of Fuel Gas (FG) inside the furnace box for about 40 min prior to going for burner lit-up.
- ✓ No steam purging of furnace was done just before burner lit-up. It was done about 1.5 hr. earlier.
- ✓ Flow indication of FG through burners for about 40 min (without burners being lit-up) was not noticed at DCS panel and no alarm was raised.
- ✓ Lighting of main burner was done without lit-up of Pilot burner against SOP guideline- Normalization of deviation

- ✓ **Adhere to SOP**
- ✓ **Regularly review and improve SOP**
- ✓ **Training need to be regularly identified**
- ✓ **Ensure Internal audit recommendations are implemented in time bound manner**
- ✓ **Implement Concept of checklist in startup and shutdown activities to ensure the correct sequence of operation and time required**
- ✓ **Practice written instructions and ensure acknowledgement of all concern**

# LPG Bullet Mishap

Fatal incident took place during the degassing process of 150 MT capacity above-ground LPG storage bullet of a Bottling Plant



# Bullet Top

In order to speedup the process of degassing of bullet, water filling through top manhole was attempted which eventually led to the accident



# Major Observations

- ✓ Non Compliance of Standing Operating Procedures (SOP)
- ✓ Poor understanding of procedure
- ✓ Lack of supervision by plant personnel and Contractor
- ✓ Non-compliance of Work permit system
- ✓ Emergency handling response
- ✓ Lack of exposure/ proper training to Officers
- ✓ Recording and review of log books/ dip book

- ✓ **Comply SOPs**
- ✓ **Review SOP and Share horizontally**
- ✓ **Improve Supervision of work**
- ✓ **Clearly define Third party responsibility in Contract**
- ✓ **Train and test your Contractor**
- ✓ **Ensure adequacy of Equipment for rescue operation**

# VCE AT TANK LORRY FILLING GANTRY

**Explosion followed by Flash Fire occurred which engulfed 3 tankers and resulted into fatal injuries**



# VCE AT TANK LORRY FILLING GANTRY



Initiation



# VCE AT TANK LORRY FILLING GANTRY



तेल उद्योग सुरक्षा निदेशालय

Oil Industry Safety Directorate

# Major Observations

- ✓ **Earthing failure**
- ✓ **Disregard of procedures /safety guidelines**
- ✓ **No check to ensure earthing correctness (Ineffective supervision)**
- ✓ **Deviation in operation in TAS( “connect earth” alarms” were ignored )**
- ✓ **Inappropriate protective clothing**
- ✓ **Evidence of training was missing**
- ✓ **Escape route was not available to TT crew at bay no. 1**
- ✓ **In case of excess fill, Unloading bay was not used, locally collected in drums**

- ✓ Ensure static electricity is dissipated during loading operation
- ✓ Ensure absence of MS vapors or liquid in case of switch loading
- ✓ Ensure no safety interlock is by passed during loading
- ✓ Strict adherence to the work procedures
- ✓ System for identification of unsafe acts and conditions and its reporting by the operating personnel shall be strengthened at the organization level
- ✓ Compliance of audit observations
- ✓ Train contract staff and workers
- ✓ Use of correct protective clothing
- ✓ Convert all top loading tank lorry filling gantries to bottom loading with vapour recovery system in a time bound manner

ExxonMobil \_ Faulty Valve design in use  
(normalization of deviation)

ExxonMobil\_FCC Fire  
(Improper HAZOP in MoC)

तेल उद्योग सुरक्षा निदेशालय

Oil Industry Safety Directorate

# Suggestions for Safety improvement

- a) Improvement in the quality of risk assessment
  - Improve Risk Screening ( risk screeners, Risk assessment leaders)
  - Strengthen the implementation system
  - Introduce a system to re-evaluate past risk assessment results  
**(ExxonMobil case- Electrostatic pptr blast )**
- b) Continual Improve training program for process safety
  - Focus on internal capacity building for HAZOP, QRA
  - (use of VR for Risk experience)
- c) Suggestion scheme/ pocketbook on safety
- d) Fostering a continuous safety culture to raise safety awareness-  
(Have your own Safety Day)



**THANKS**

तेल उद्योग सुरक्षा निदेशालय

Oil Industry Safety Directorate



SAFETY OF THE PORT



[Back](#)

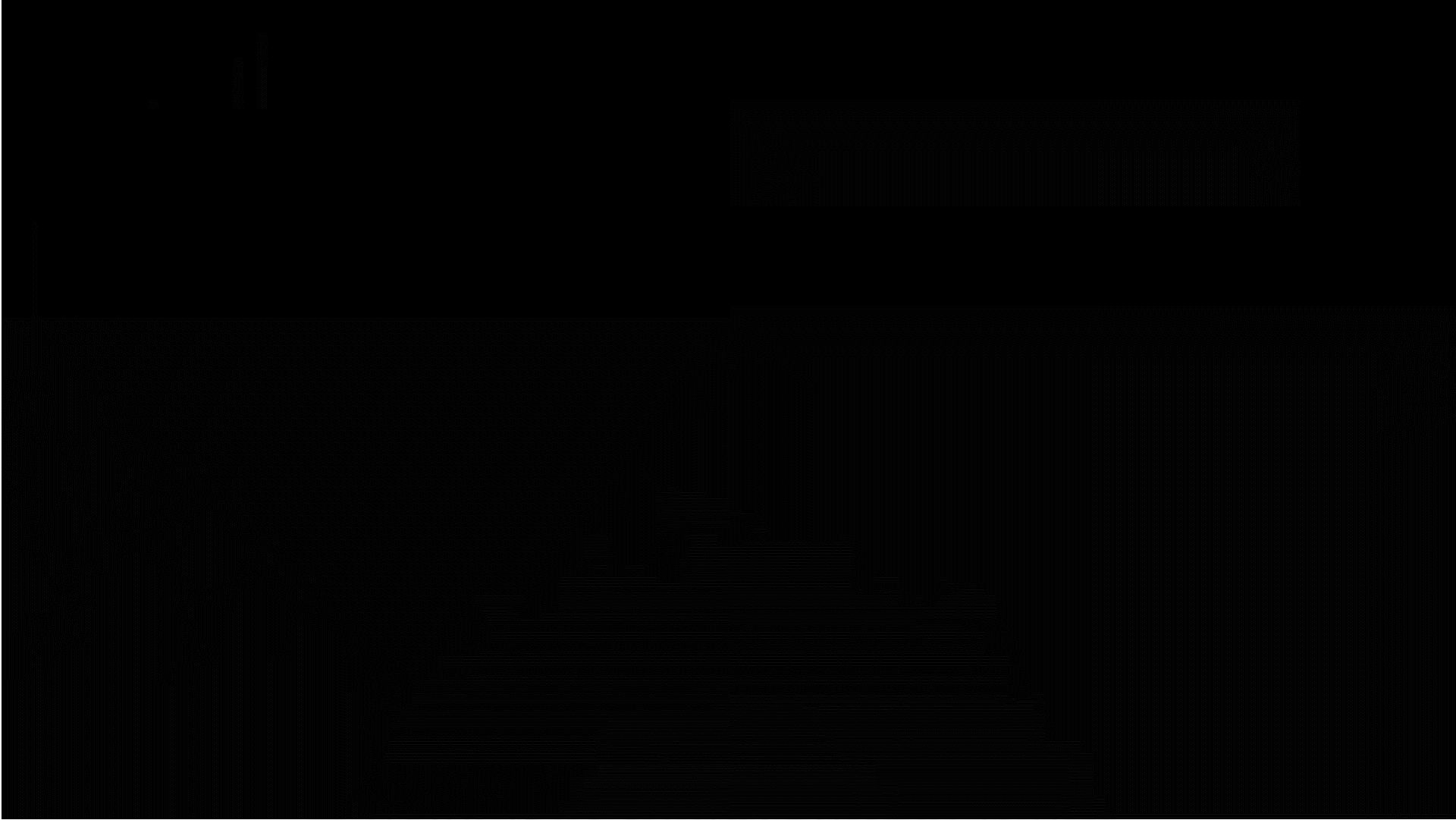

© 2010 Pearson Education, Inc. All rights reserved. This material is intended solely for the personal use of the individual user and is not to be disseminated broadly.

 [Back](#)

# Static Electricity

MATEC Web of Conferences 343, 10013 (2021) <https://doi.org/10.1051/matecconf/202134310013> MSE 2021

## Conclusion of the Study

With the advent of new types of fuels, ULSD (Ultra Low Sulfur Diesel), as a result of the implementation of environmental legislation, has increased the risk of explosion, because these types of diesel are easily charged with static electricity and discharges with sufficient energy can occur to ignite an explosive atmosphere.

Therefore, oil companies need to review their working procedures with additional measures to prevent explosions. These procedures must implement measures to prevent switch loading and eliminate initiation sources.

In order to achieve this, a cooperation arrangement between the road tanker operator and the site operator is indispensable for purposes of implementing safe loading and unloading procedures with the goal of mitigating the risk of explosion.

Back