

Capacity Building Workshop For Third Party Inspection Agencies

Mayur Vihar Delhi
(24th Feb 2025)



ERDMP Academy LLP
(NABCB Accredited Institute)
erdmpacademy@gmail.com
Contact 9893250923



National Workshop

"Accreditation of
Emergency Response and Disaster Management Plan (ERDMP)"
for Oil & Gas Companies
(28th February – 1st March 2011)



Supported by
Petroleum & Natural Gas Regulatory Board
&
Ministry of Chemicals & Fertilizers / Industrial Disaster Management
Institute

Journey begins for ERDMP certification by inauguration of 1st workshop at Bhopal by Hon'ble Minister Sri Rajendra Shukla, MP Govt , and Chairman PNGRB, Member PNGRB, ACS and Secretary MP Govt, etc. on 28 Feb 2011



**Inauguration of 2nd workshop at Bhopal by
Chairman PNGRB, Member, ACS and
Secretary MP Govt, etc.**



DMI

5th

National Conference on

Capacity Development of City Gas Distribution (CGD)

Projects for Certification of Emergency Response & Disaster Management Plan (ERDMP)

Organized in Collaboration with Petroleum and Natural Gas Regulatory Board (PNGRB), Government of India



PNGRB

14 Feb 2020

Disaster Management Institute
Department of M...

**5th Workshop on ERDMP Capacity Development
14th Feb 2020**

Presentation
focussed
on/Agenda

Understanding of ERDMP Regulation
2010/20: Perception guides about the
audit

Process of Audit/Certification

Challenges

Way head

Architecture of ERDMP Document

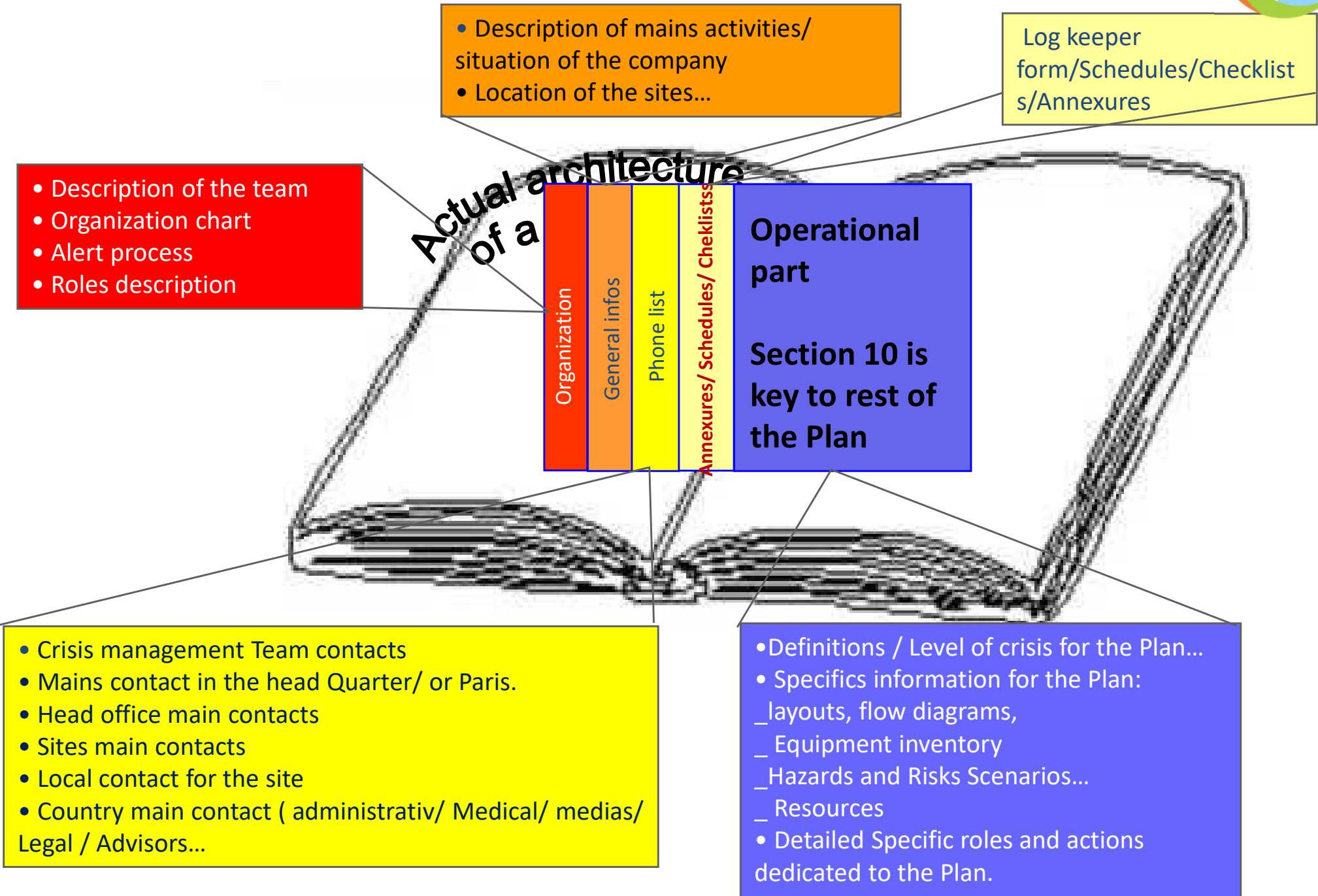

Important Regulatory provisions and Standards

- **Environment (Protection) Act 1986**
- First initiation against **On-site (Schedule 11 and Off-Site (Schedule 12) of Manufacture, Storage and Import of Hazardous Chemicals of Rules 1989** (*never certified or approved*)
- **Chemical Accidents (emergency planning, preparedness and response) Rules 1996 : CCG, SCG, DCG, LCG**
- **Emergency Response and Disaster Management Plan (ERDMP) regulation 2010** for mid and down stream oil and gas sector companies
- Both schedules are **one page each** while ERDMP regulation is about 60 pages i.e. Objective is to have an effective and better operational manual for Emergency response. (**Prevention and mitigation**) (Certified for three years with annual drills)
- State rules accordingly (Factories Act 1948)
- **Central Motor Vehicle rules 1989**
- **Hazards Identification and Risk Assessment BIS (2006) IS 15656**
- **Disaster Management Act 2005 : DDMA/SDMA (section ...to notify DCG/SCG as specialist advisor for chemical/industrial disaster management**

Key Focus of ERDMP Certification

Section 1-5 :- General

Section 6 :- Classification of emergencies

Section 9:- Other statutes

Section 10:- Pre-emergency

- 10.1:- Hazards identification
- 10.2 Risk analysis and risk assessment.
- 10.4 Consequences.

(1) The consequences of an Incident may be confined within the premises or may spill off-site triggering cascading effects.

(2) The consequences of an Incident are fire explosion, deflagration, blast waves, fast spreading flames, BLEVE, VCE, toxic release, Boil Over etc. resulting in direct effects like damage to buildings/property, burns, fatalities.

13.0 Response Procedures and Measures.

- Containing the consequences of an emergency requires well planned and documented procedures to ensure prompt response and coordination among various task groups. The following response procedures as prevalent in the location shall be carried out:
- (a) Zoning and Maps.
- (i) The zones and maps shall be prepared highlighting the Incident prone areas of the unit so that in case of an emergency it serves as a basis for taking the action. This indicates the size of the area within which human life is seriously endangered by the consequences of incident. This should also indicate the location of assembly points and emergency control rooms. The map should also have marked 24 wind directions to facilitate easy access in case of emergencies.
- (ii) The entities shall help District Disaster Management Authority (DDMA) in finalizing the full drawn map of installations and nearby areas under their operations having presence of habitats which are vulnerable and sensitive like old age homes, schools, prison, etc.

Consequence modeling??

Incident

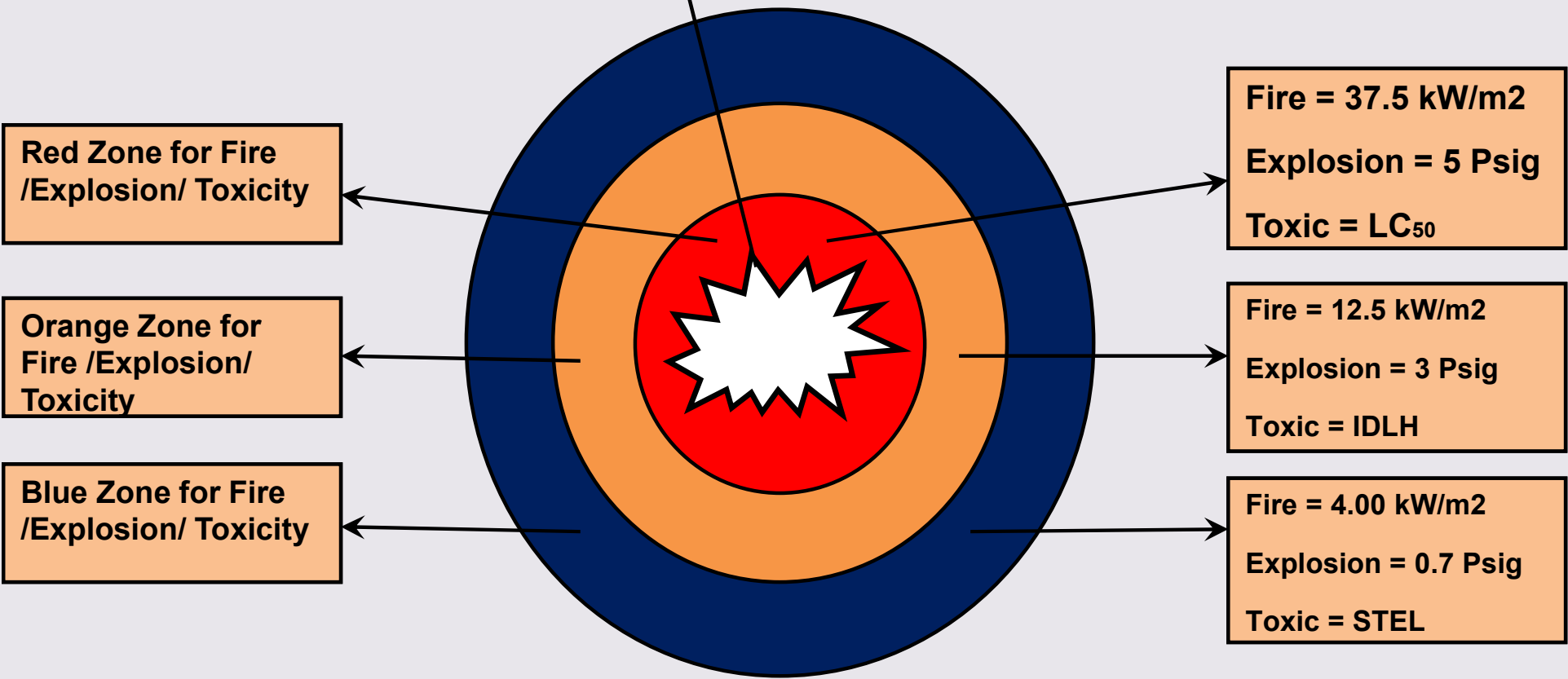

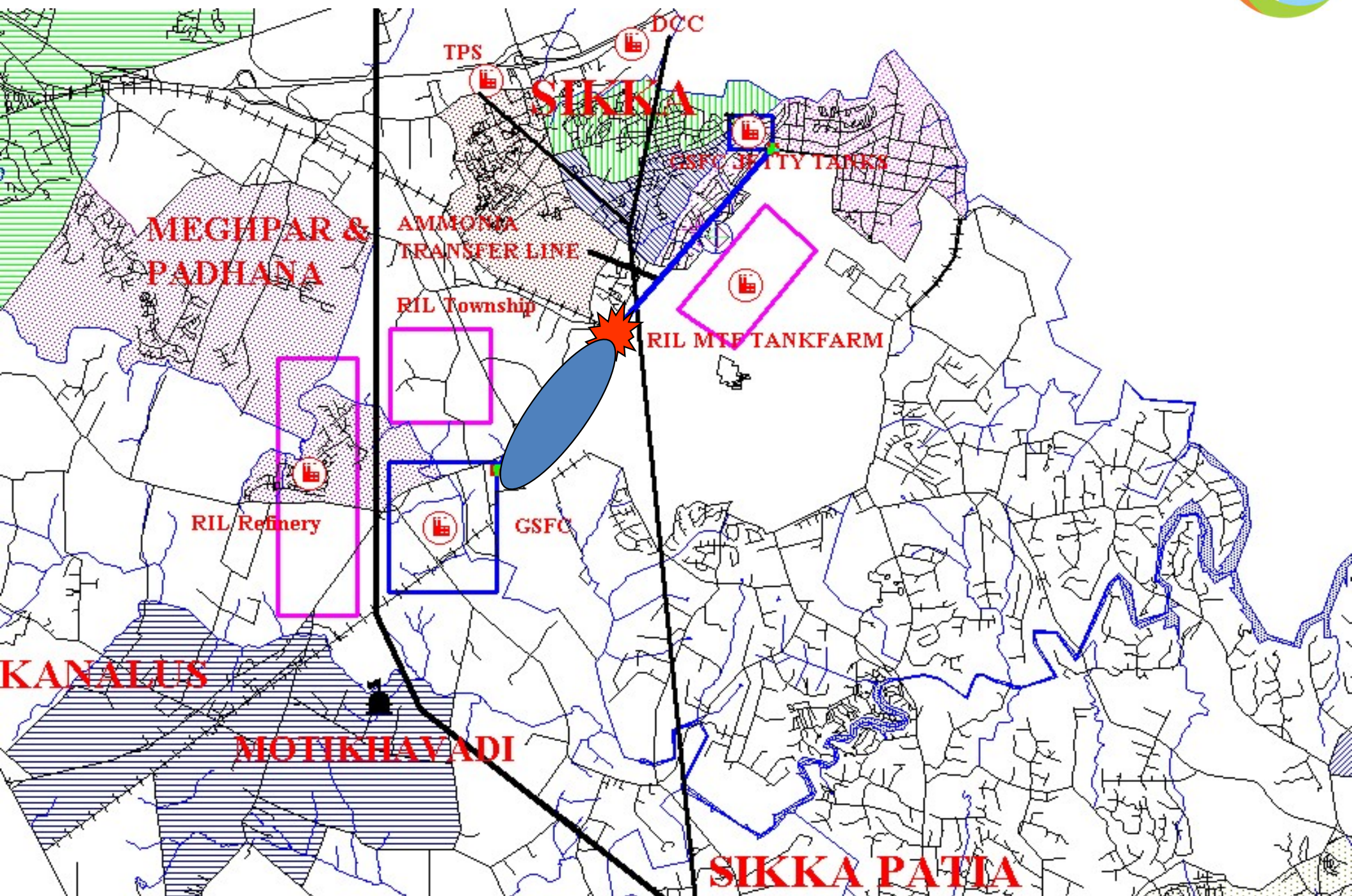

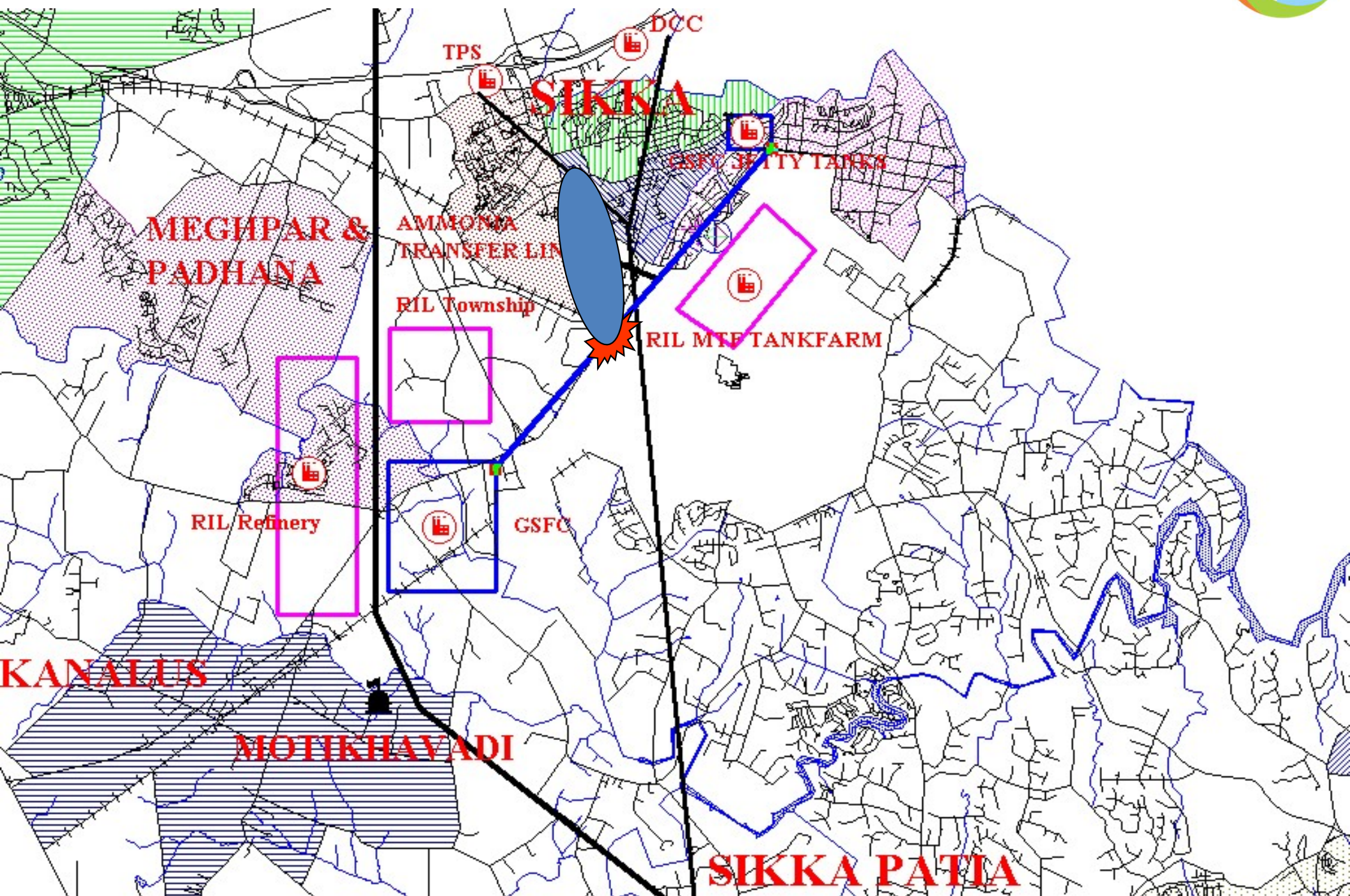

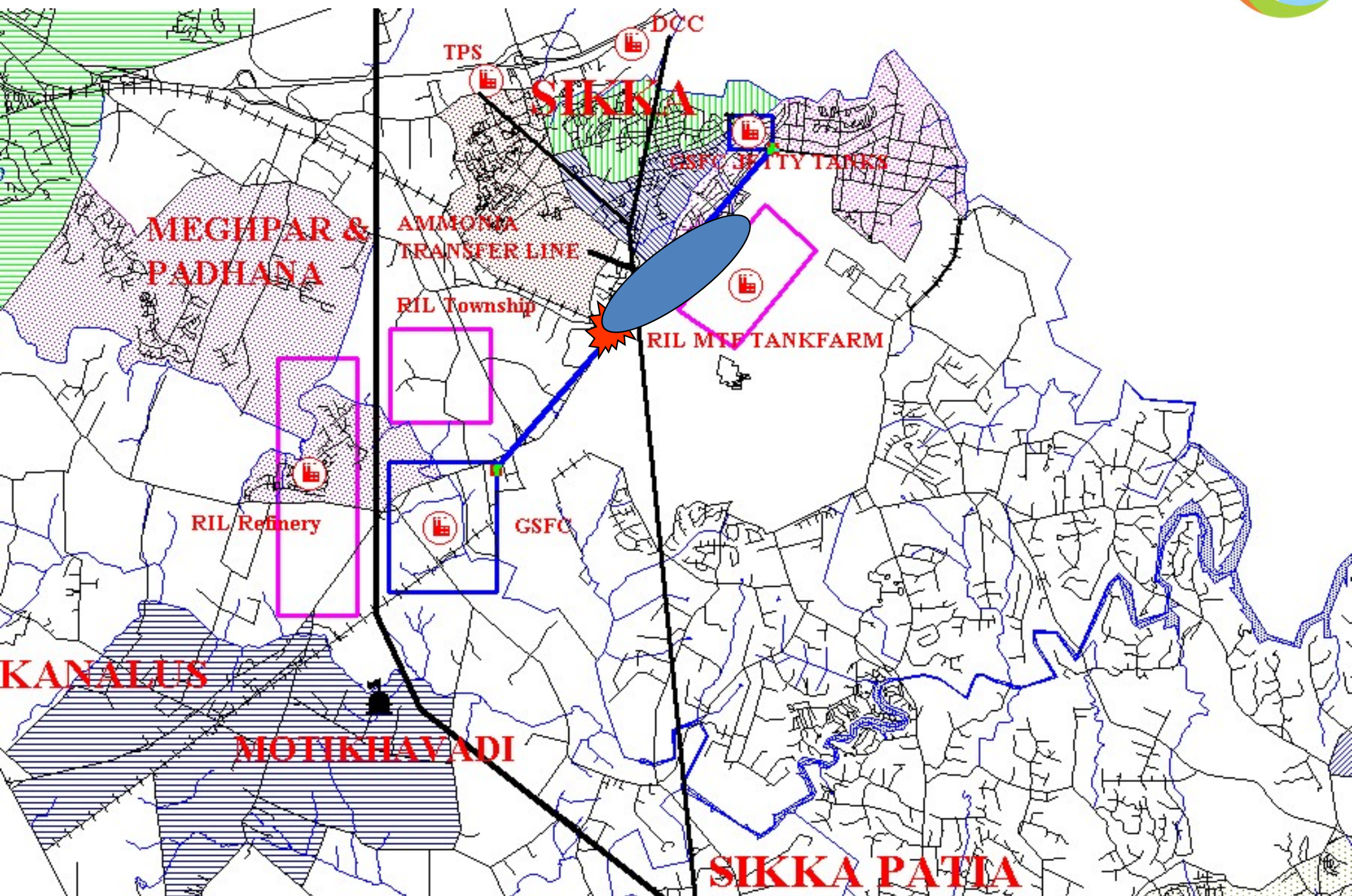

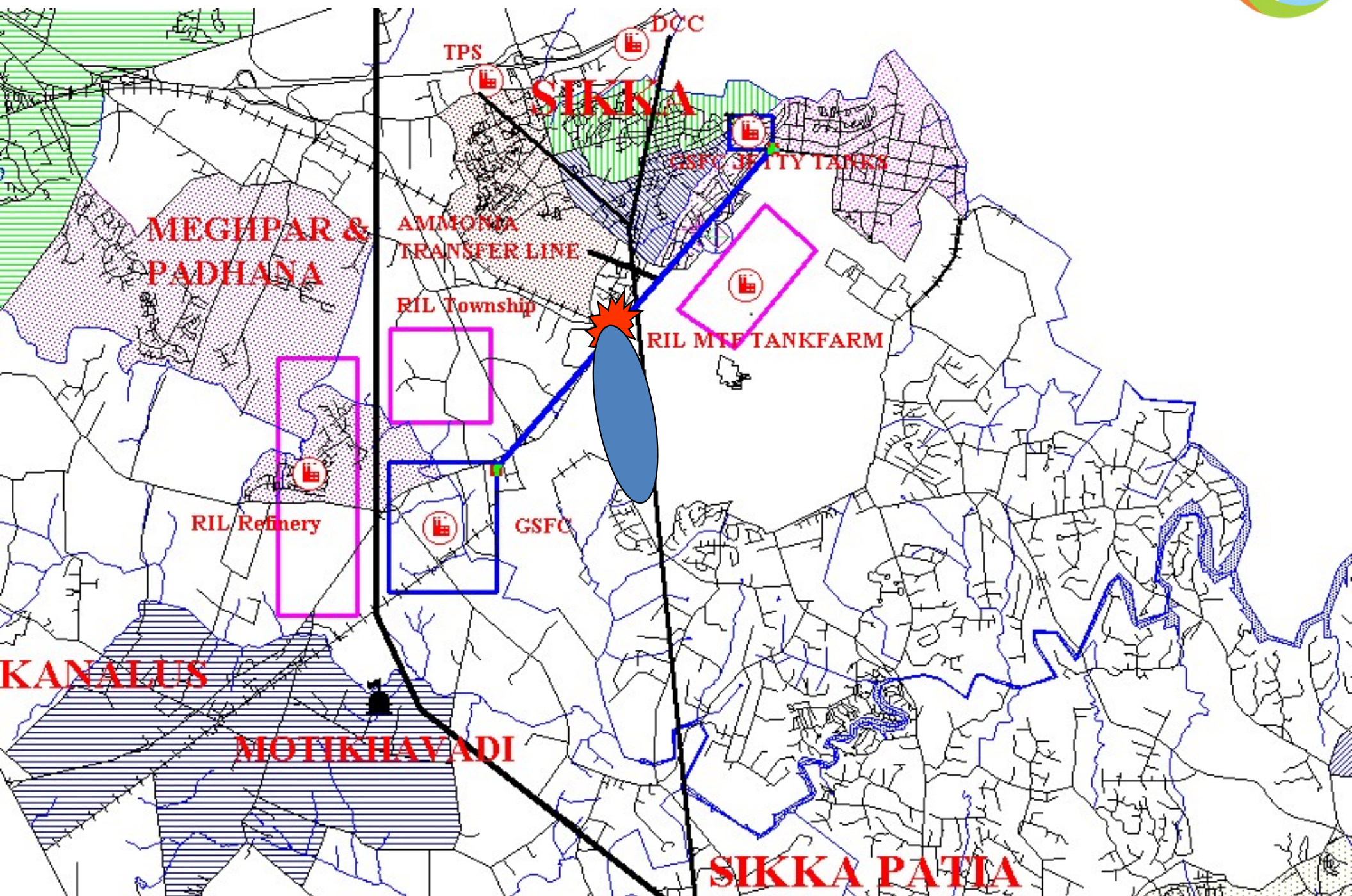

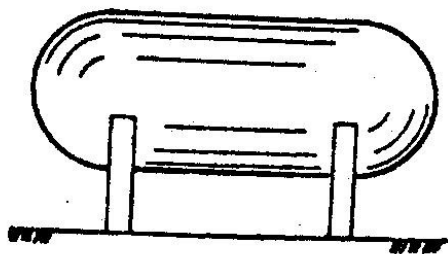

HORIZONTAL CYLINDRICAL
TANK

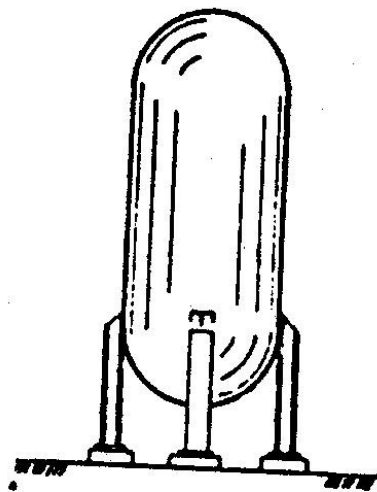

VERTICAL
CYLINDRICAL TANK

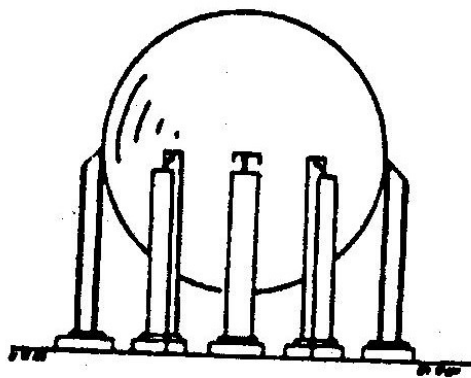

SPHERE

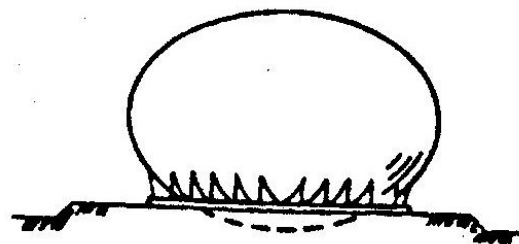

SPHEROID

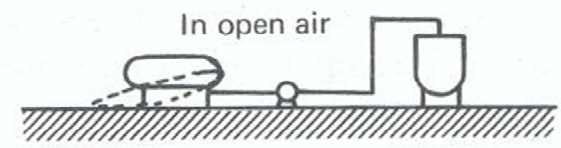
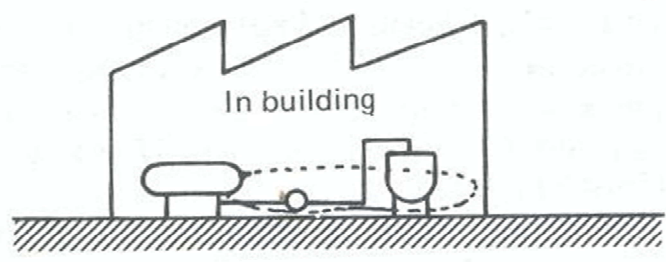

(d)

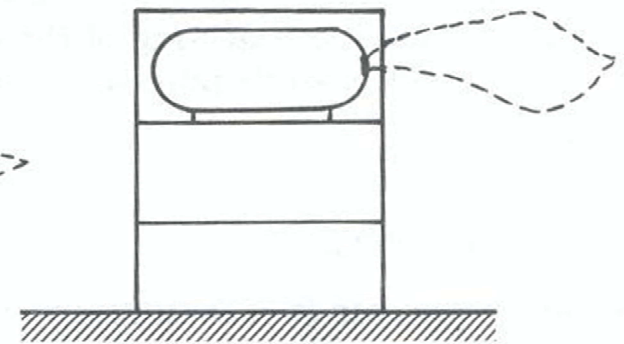
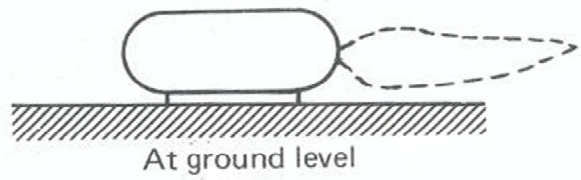
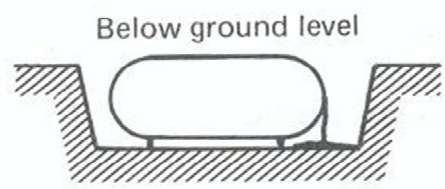

(e)

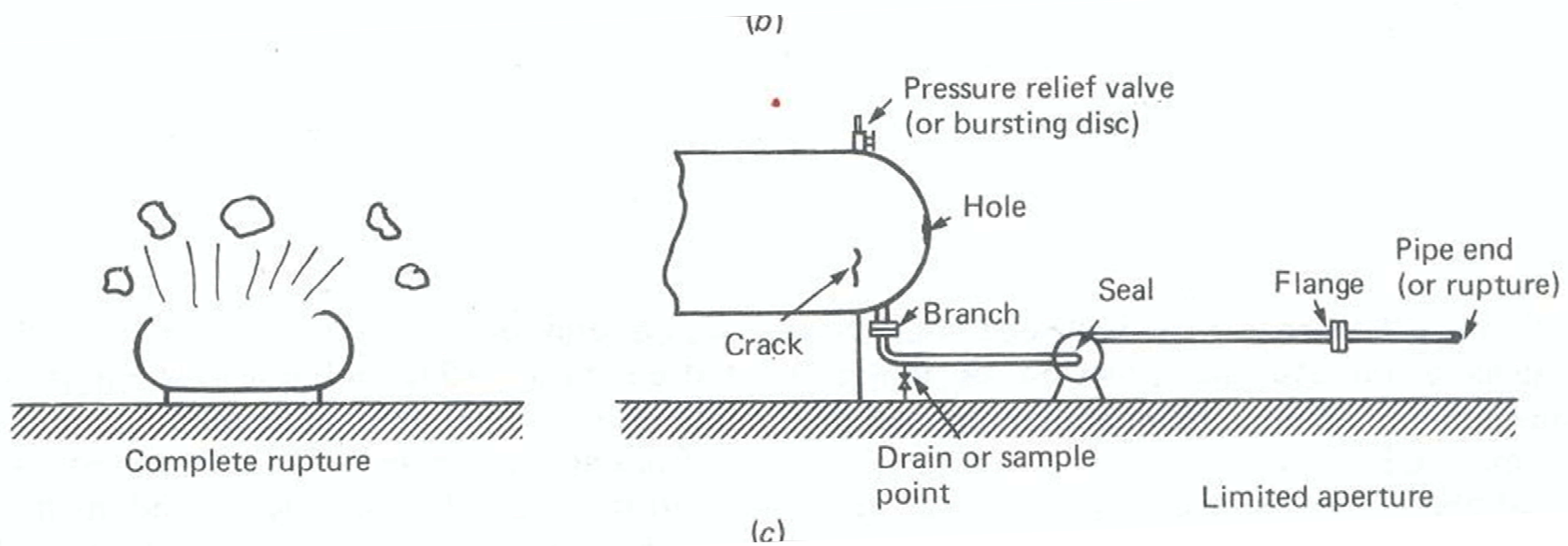
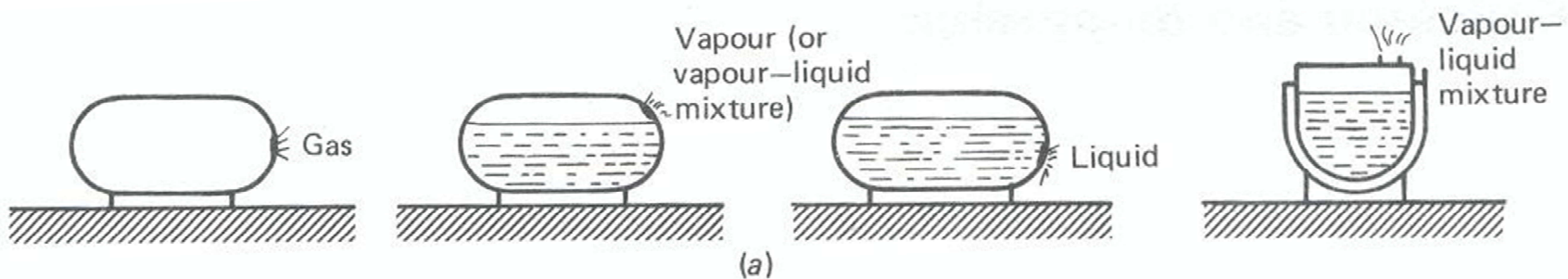

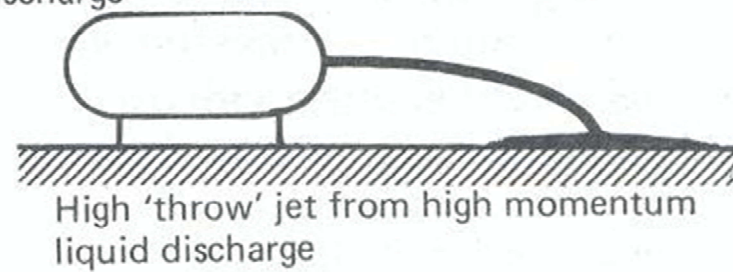
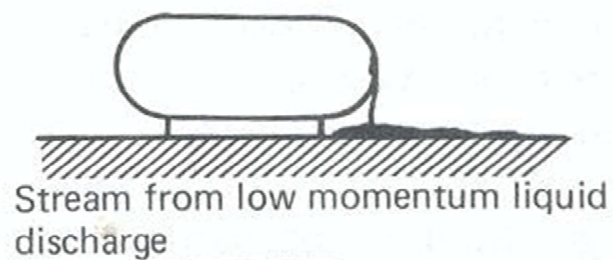
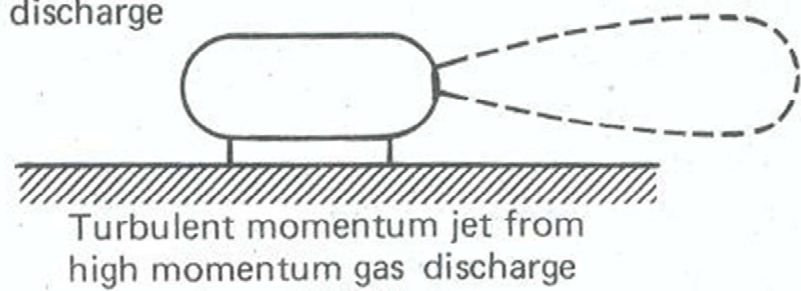
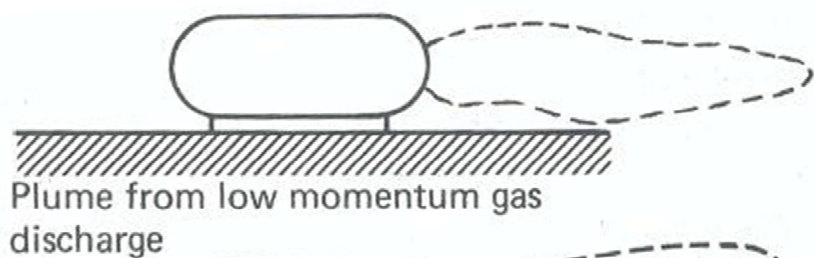

(f)

Multiple sources

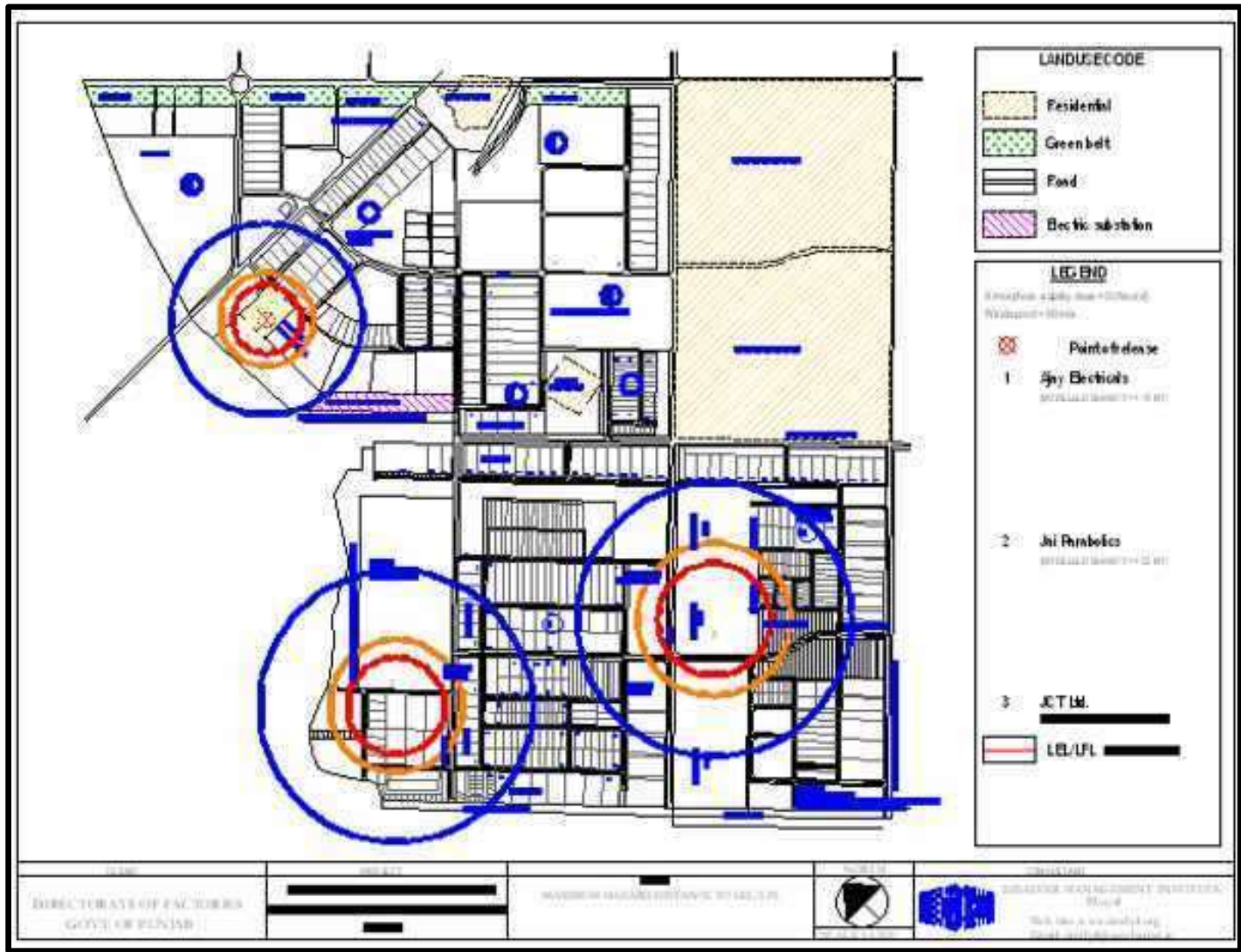

Multiple sources

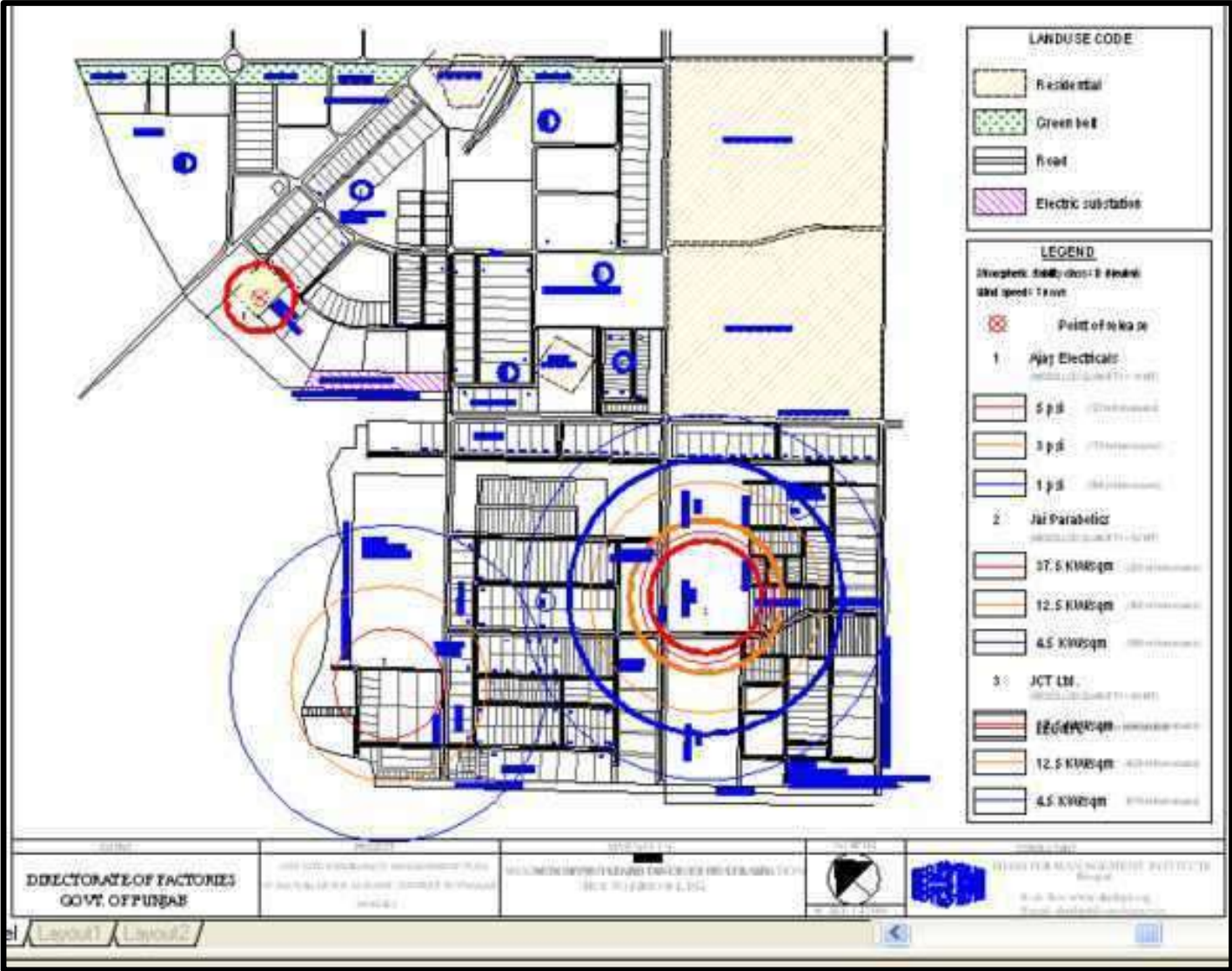

Regional issues?? districts-district, state-state? DCG/DDMA vs DDMA/SDMA

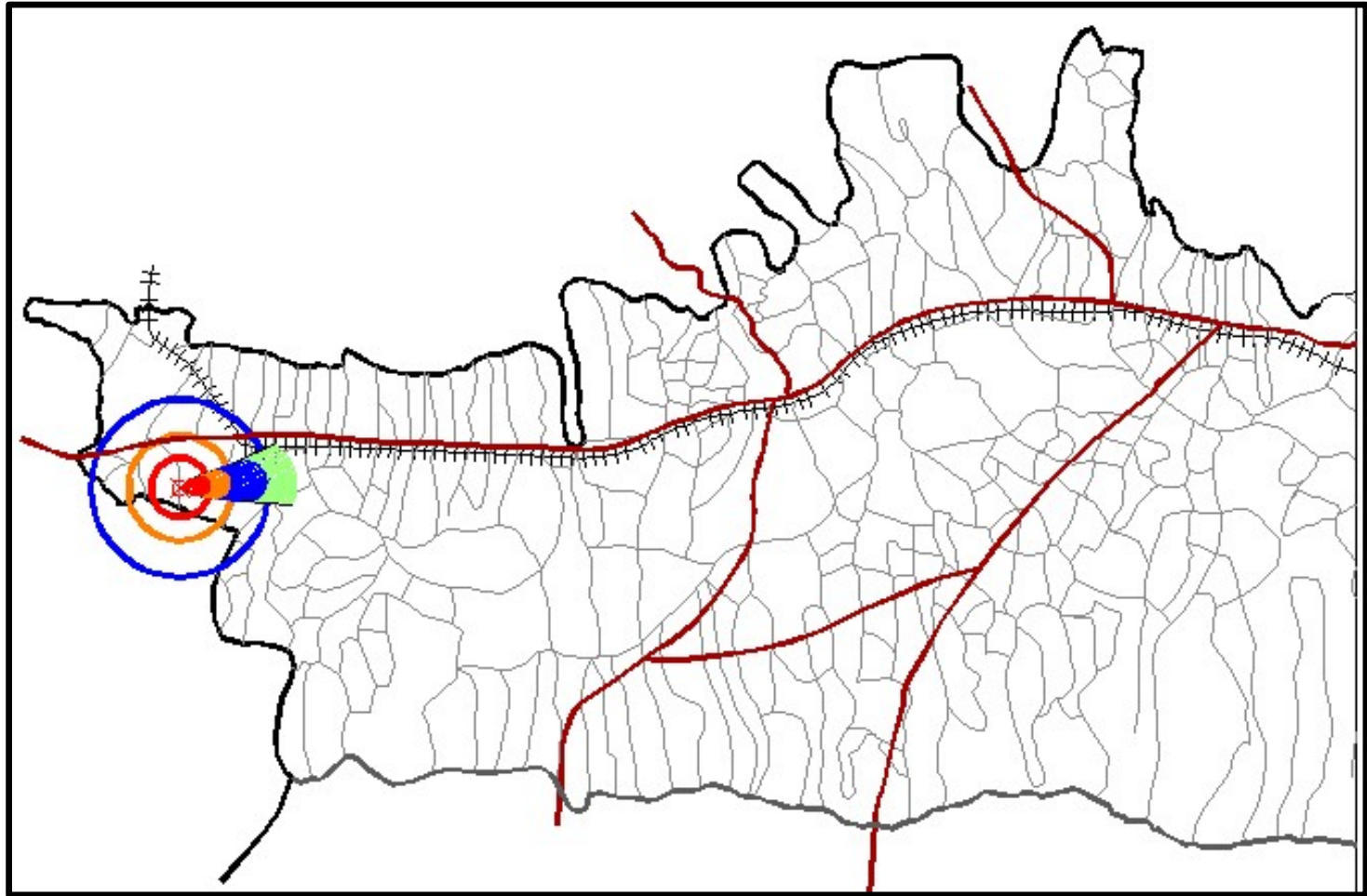

Challenges:-

Clarity for
ERDMP Audit
and other
audits?

- ESA IS 14489:2018
- OISD Audit
- Internal Audit
- ERDMP Audit (On-site and Off-site)

Challenges:- Traceability ?



Desk Audit of the document by TPIA

Review and evaluation of the document in field



What auditors are auditing ?

Focus on Physical audit



Compliances ?

Compliance of Audit done at field



Numbers of auditors and numbers of days ?

Job specification by each auditor

Conclusion:-

**Way head
Laying down
further guidelines
/ requirements for
harmonization and
further
improvement in the
quality of
inspection
activities**

- Regulatory conflict resolution with state agencies with Factories Act/MSIHC provisions vs Certification of ERDMP
- Capacity building of auditors should be enhanced to understand QRA, HAZOP with respect to Section 10 and 13 of regulation
- Uniform process of inspection and the documentation.
- Annulment of certification if entity is not doing the annual drill in presence of TPIA.
- Time bound permission is needed for Team for audit.
- Auditors panel may be made available at PNGRB website for inclusion of competent auditors.
- Trainers should be identified who understand the subject irrespective of Oil and Gas field.
- L1 is a big challenge for quality
- Since TPIAs are working on behalf of PNGRB hence regular meeting and hand holding is required.
- ERDMP Academy is ready to impart training to auditors
- Annual workshop for entities on ERDMP capacity development



Leadership is needed.....

Visionary role

Doing the
right thing

Implementation role

Doing things
right



Questions
or
Observations

Thanks